



 **Castings
Engineered
For future**

An ISO 9001:2015 company



PRIMARY CASTINGS PRIVATE LIMITED (PCPL) an ISO 9001:2015 certified company and is one of the leading foundry in the manufacturing of Grey Iron and Ductile Iron Castings here in West Bengal, India. Today, it is one of the most renowned foundries with a successful legacy in the manufacture of quality castings. With its foundry in Eastern India, it is supported by highly qualified and experienced engineering staff and a very efficient team of skilled workers. The company has a combined annual capacity of 14,400 MT per annum.

We at PCPL, strive to combine modern technology with traditional skill together with stringent quality control measures. We have undertaken the commitment towards quality control and timely delivery of produced goods. As a result, we have established an appreciable clientele in the discerning markets all over world.

Being one of the pioneer leading manufacturers and exporters of cast iron and ductile iron products, the company has been producing both precision and heavy duty items confirming International standards since day one of its existence.

The company is engaged in producing the following product range:

- Sanitary Castings like Square, Round, Rectangular manhole covers and Gratings in
- Grey Iron and Ductile Iron.
- Industrial Castings like flanges and Counterweights.
- Mild Steel Fabricated Drain Covers.
- Pipe fittings

We at PCPL, implement an ascetic quality control system, which is customer oriented and is continuously improved.

To accomplish our targets, we follow the policy of constantly motivating and developing the competent human resources to cope with the variable customer requirements. In addition, we try to attain higher productivity level together with improved quality performance to achieve maximum customer satisfaction.

Our highly qualified engineers and a state-of-the-art R&D unit ensure that our products are of the superior quality. The produced goods undergo a complete physical testing including Casting's Hardness, Load Testing, Load Tensile, Transverse and Chemical Analysis to meet the requirements of the globally accepted quality standards.

Today PCPL is a rising International Star with a rapidly growing export market and a commitment that places customer above all else. Currently, our export constitutes 86% of our turnover.

We at PCPL, continue our journey of growth, taking on new challenges and going beyond these, unswerving from our search for excellence and growth, at home and overseas. We invite you to join us in our journey and together, strive to grow beyond boundaries.





QUALITY ASSURANCE



PRODUCT SELECTION



CLASS A15

Loading Strength -
15kN Pedestrian Areas

CLASS B125

Loading Strength -
125kN Footways, Pedestrian
areas and Car parks

CLASS C250

Loading Strength -
250kN Kerbside Panels of
Roads and car parks

CLASS D400

Loading Strength -
400kN Carriageways, Hard
Shoulders and Parking Areas

CLASS E600

Loading Strength -
600kN High Wheel Load Areas,
Docks and Aircraft pavement

CLASS F900

Loading Strength -
900kN Very High Wheel load
Areas - aircraft pavements





Melting System

- > 650 KW Induction Furnace with 2 Nos. Crucibles of 1.0 MT each
- > Cupola Furnace-5.0 MT per hour

Moulding System

- > ARPA 450 (one pair) with Box Size- 680 MM x 730 MM
- > Floor Moulding Rammers

Sand System

- > Semi-Automatic Sand Plant (300 MT per Hour)
- > CO-2 / Green Sand / Resin Sand
- > Sand Used =Silica Sand, Chromite Sand and Yellow Sand
- > Sand Mixers for no Bake Sand System
- > Various Mullers of 200-500 Kgs
- > Extensive Pollution & Dust Extraction System

Sand Reclamation

- > Sand Crushing with Dust Collector

Core System

- > Co-2 / Resin / Phenolic Urethane No Bake

Finishing Facility

- > Hand Fettling and Grinding / Shot Blasting
- > ARC and Gas Cutting
- > Welding Machine

Pattern Making

- > Semi Equipped in House Pattern Shop
- > Making Patterns in Aluminium / Cast Iron / Wood (Outsource)

Handling System

- > 5 Tonne EOT Crane
- > 5 Tonne EOT Monorail
- > Fork Lift

Electrical Equipments

- > Transformer
- > VCB
- > Air Compressor
- > Cooling Tower

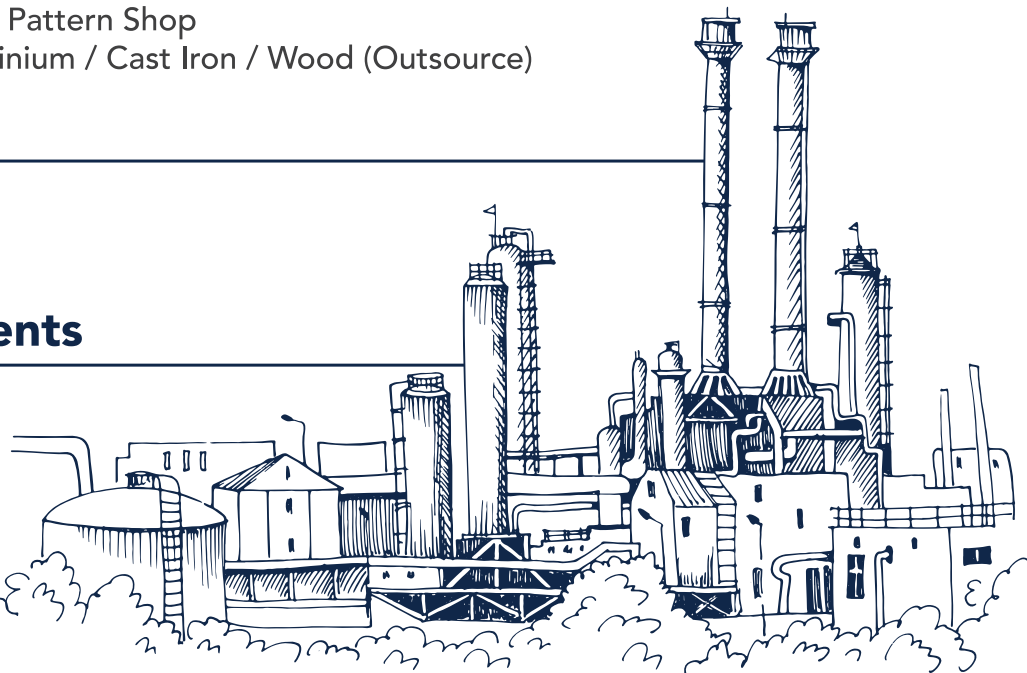



- Compactibility Tester
- Digital Permeability Meter
- Digital Moisture Meter
- Universal Digital Strength Machine
- Core Hardness Tester
- Mould Hardness Tester
- Cly Washer
- Sieve Shaker
- Methylene Blue Clay Tester



- Spectrometer by Spectromaxx
- Micro Analyser for Microstructure
- UTM Machines
- BHN Testing
- Load Testing of 120 Mt
- Tilt and Pull out Test for EN 124-2
- Coating Thickness Tester
- Carbon Silicon Analyser
- Immersion Pyrometers to Check Metal Temperature
- Hydrometer for Measuring
- Liquid Density Load Testing Machine



- Strohlein Apparatus for Determination of Carbon
- Hot Plate
- Muffle Furnace
- Titration Apparatus

SINGLE SEAL SOLID TOP FRAME AND COVER (B125)

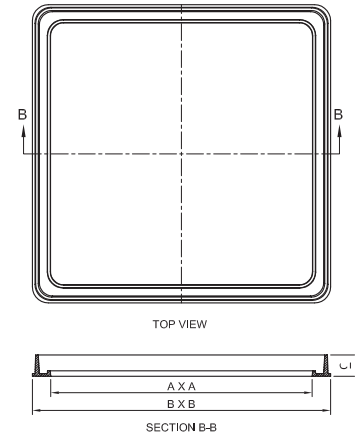
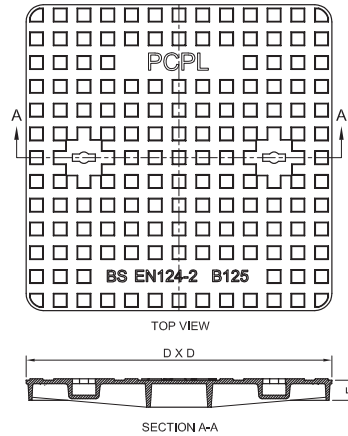
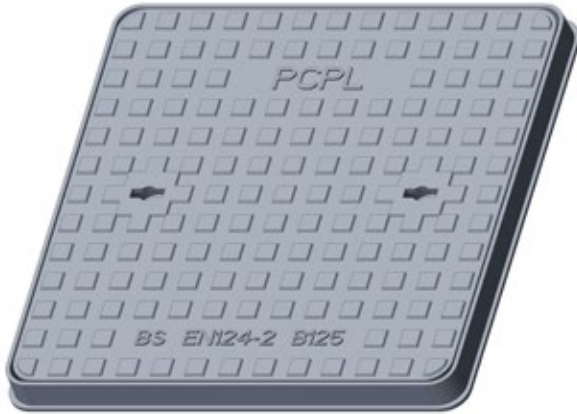

SL. NO.	CLEAR OPENING (A X A)	FRAME (MM)		COVER (MM)	
		OVER BASE (B X B)	HT (C)	OUTSIDE (D X D)	HT (E)
1	300 X 300	390	50	350	45
2	450 X 450	550	50	500	45
3	600 X 600	705	50	645	40
4	800 X 800	910	50	865	45
5	900 X 900	1000	50	975	40
6	1000 X 1000	1110	50	1090	40

DOUBLE SEAL SOLID TOP FRAME AND COVER (B125)

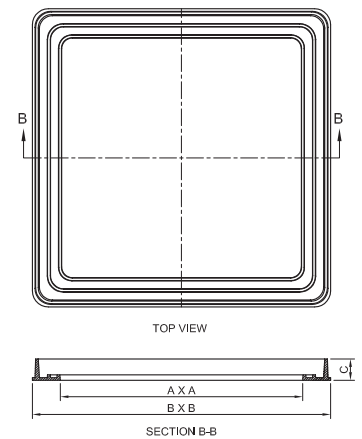
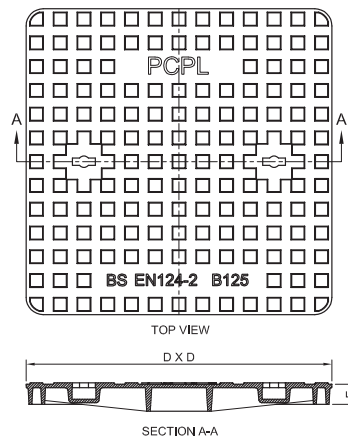
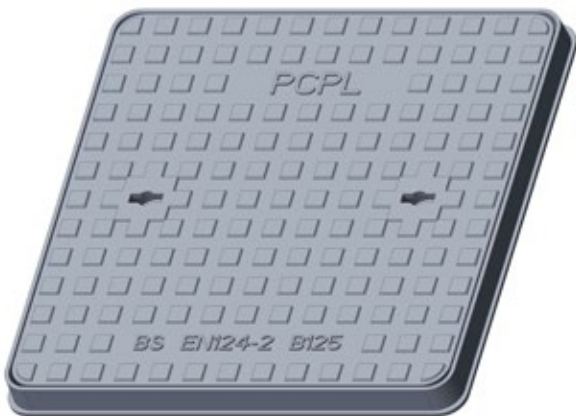

SL. NO.	CLEAR OPENING (A X A)	FRAME (MM)		COVER (MM)	
		OVER BASE (B X B)	HT (C)	OUTSIDE (D X D)	HT (E)
1	300 X 300	450	50	400	45
2	450 X 450	570	45	525	45
3	600 X 600	750	50	698	40
4	800 X 800	965	50	915	45
5	900 X 900	1060	50	1025	40
6	1000 X 1000	1090	50	1080	40

SINGLE SEAL SOLID TOP FRAME AND COVER (D400)

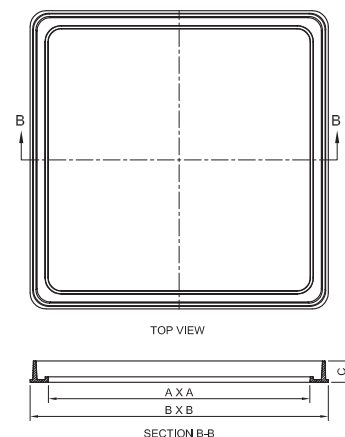
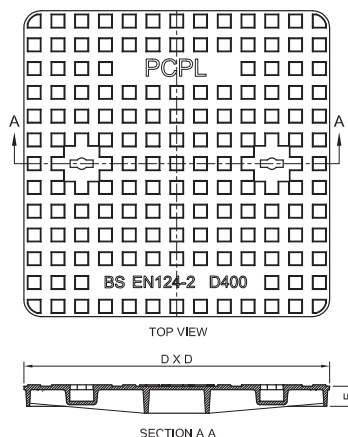
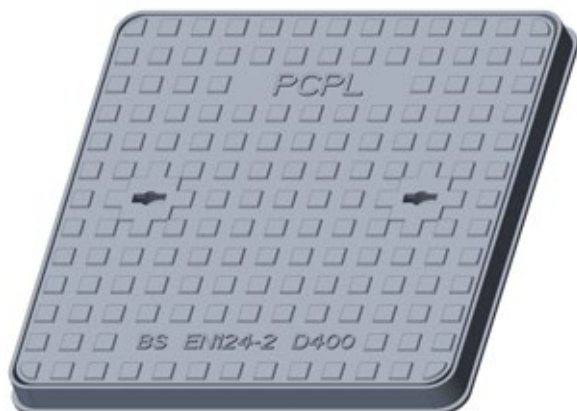

SL. NO.	CLEAR OPENING (A X A)	FRAME (MM)		COVER (MM)	
		OVER BASE (B X B)	HT (C)	OUTSIDE (D X D)	HT (E)
1	300 X 300	405	75	360	70
2	450 X 450	560	100	515	70
3	600 X 600	720	100	668	70
4	800 X 800	930	100	885	95
5	900 X 900	1040	100	995	95
6	1000 X 1000	1150	100	1100	95

DOUBLE SEAL SOLID TOP FRAME AND COVER (D400)

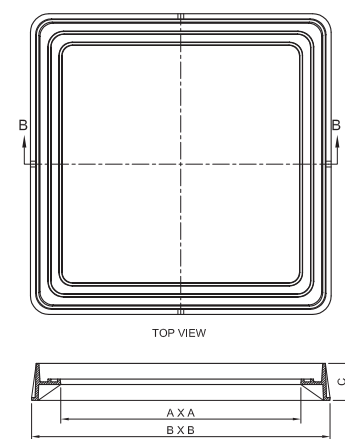
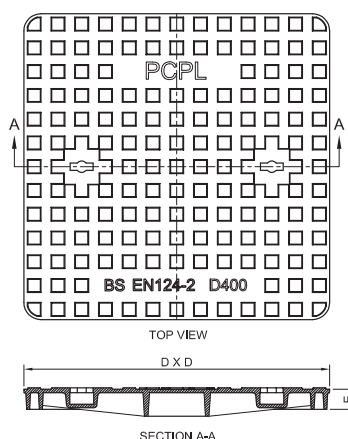

SL. NO.	CLEAR OPENING (A X A)	FRAME (MM)		COVER (MM)	
		OVER BASE (B X B)	HT (C)	OUTSIDE (D X D)	HT (E)
1	300 X 300	450	100	400	30
2	450 X 450	580	100	550	35
3	600 X 600	800	100	750	37
4	750 X 750	930	100	870	55
5	800 X 800	965	70	920	65
6	900 X 900	1050	100	995	60
7	1000 X 1000	1180	100	1100	65

DOUBLE TRIANGULAR FRAME AND COVER (D400)

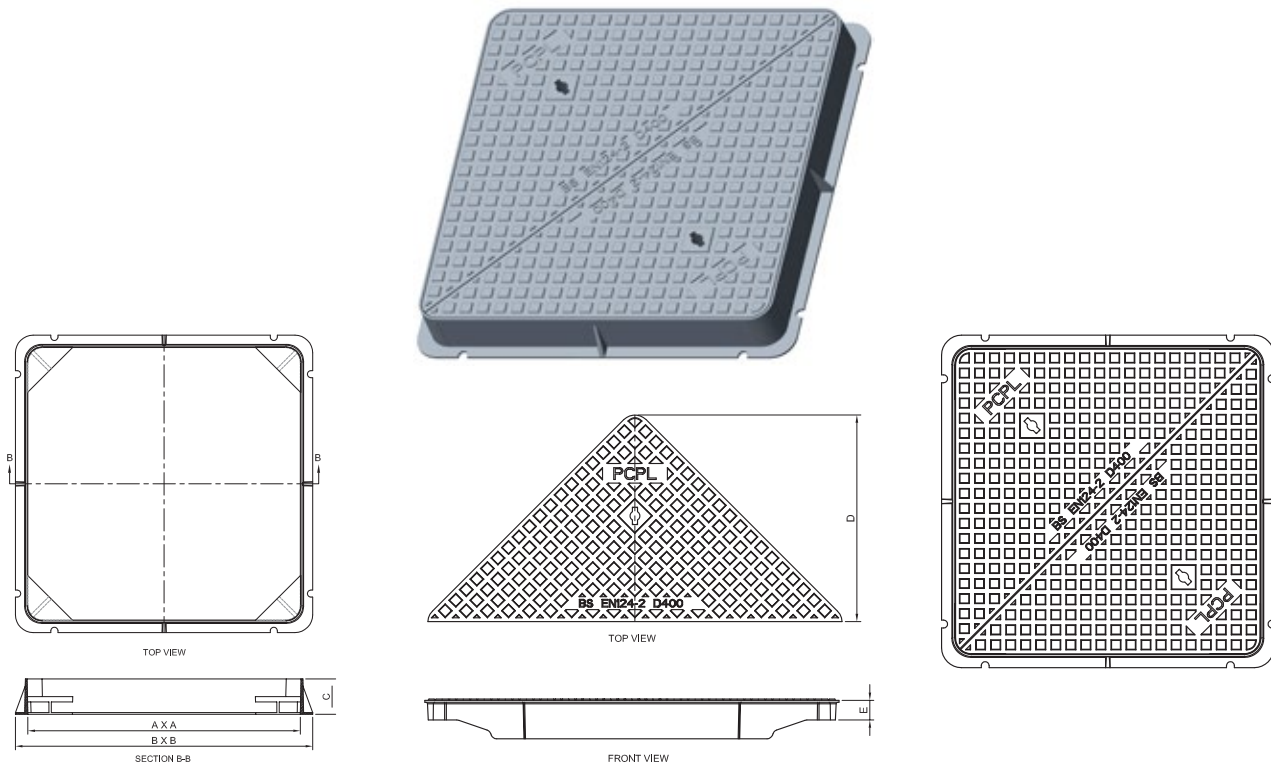

SL. NO.	CLEAR OPENING (A X A)	FRAME (MM)		COVER (MM)	
		OVER BASE (B X B)	HT (C)	OUTSIDE (D X D)	HT (E)
1	150 X 150	230	100	150	55
2	600 X 600	745	100	600	85
3	675 X 675	830	100	675	70
4	750 X 750	905	100	750	55
5	1000 X 1000	1150	100	1000	80

SINGLE SEAL SOLID TOP SQUARE FRAME WITH CIRCULAR COVER (D400)

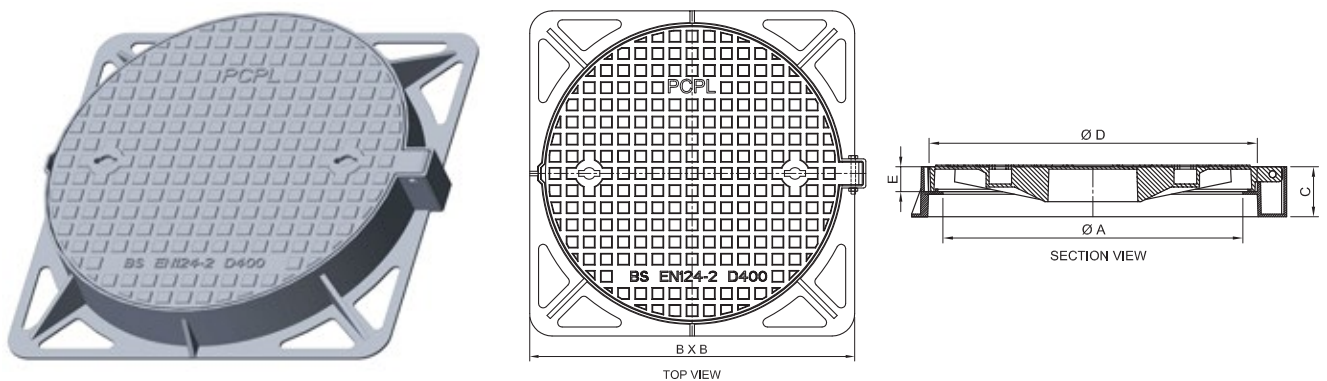

SL. NO.	CLEAR OPENING (A X A)	FRAME (MM)		COVER (MM)	
		OVER BASE (B X B)	HT (C)	OUTSIDE (D X D)	HT (E)
1	600 DIA	760 X 760	100	685 DIA	50
2	675 DIA	800 X 800	100	750 DIA	50

DOUBLE SEAL RECESSED TOP FRAME AND COVER (B125)

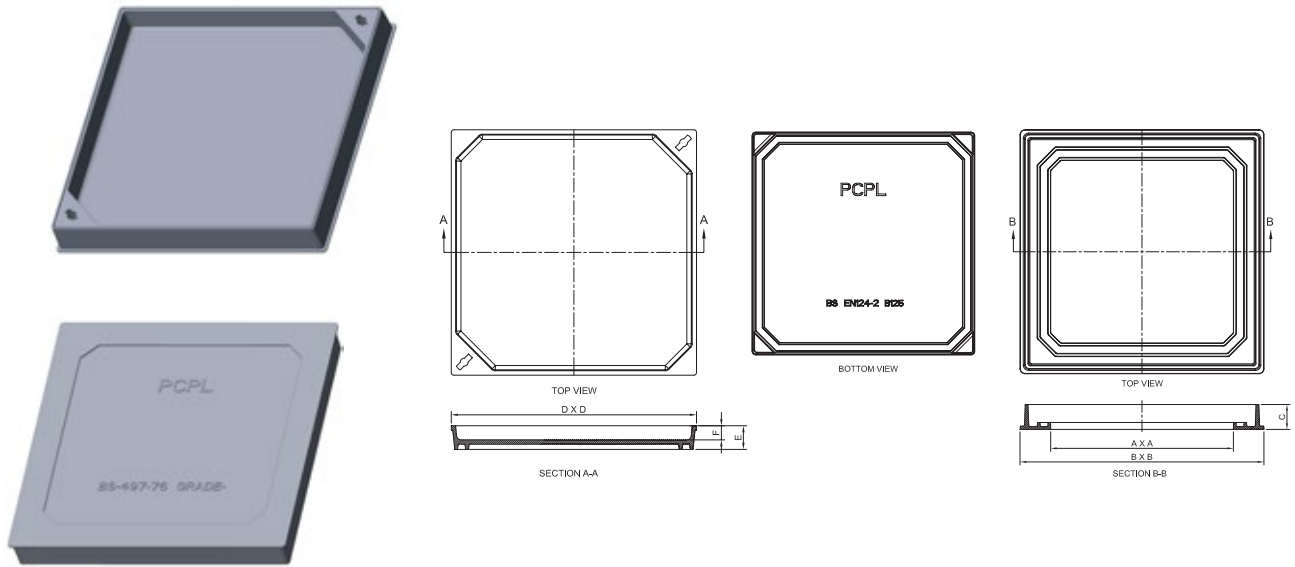

SL. NO.	CLEAR OPENING (A X A)	FRAME (MM)		COVER (MM)	
		OVER BASE (B X B)	HT (C)	OUTSIDE (D X D)	HT (E)
1	300 X 300	420	90	400	80
2	450 X 450	570	90	555	80
3	600 X 600	750	92	720	80
4	800 X 800	960	92	930	80

DOUBLE SEAL RECESSED TOP FRAME AND COVER (D400)

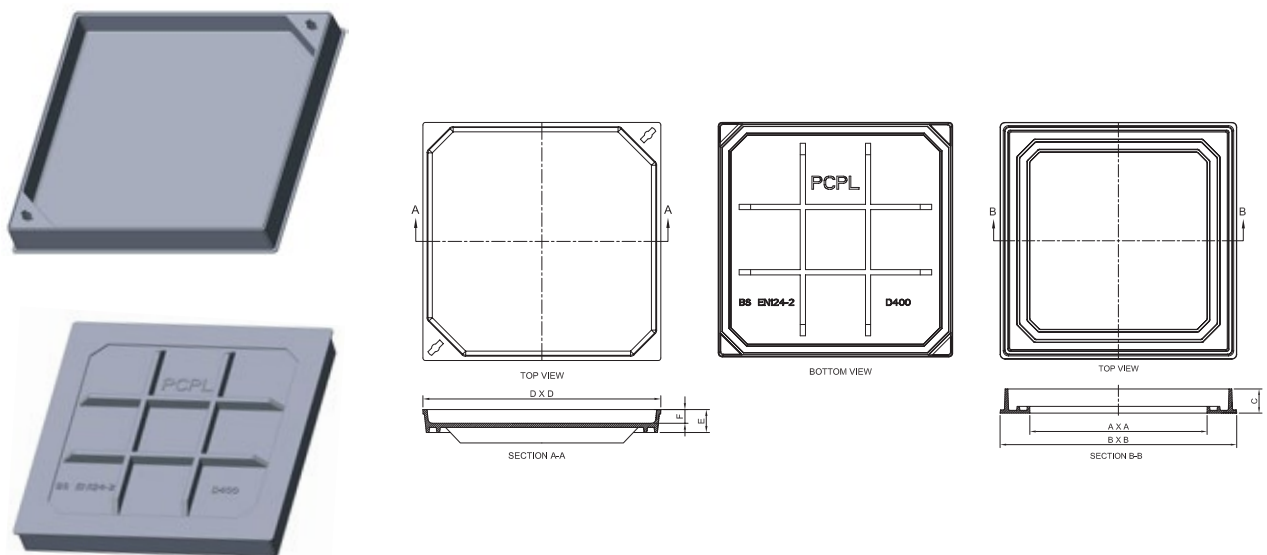

SL. NO.	CLEAR OPENING (A X A)	FRAME (MM)		COVER (MM)	
		OVER BASE (B X B)	HT (C)	OUTSIDE (D X D)	HT (E)
1	300 X 300	445	95	400	85
2	450 X 450	615	95	565	85
3	600 X 600	750	90	725	85
4	800 X 800	960	100	915	90

HINGED FRAME AND COVER (D400)

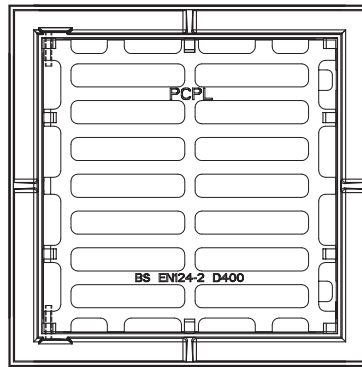
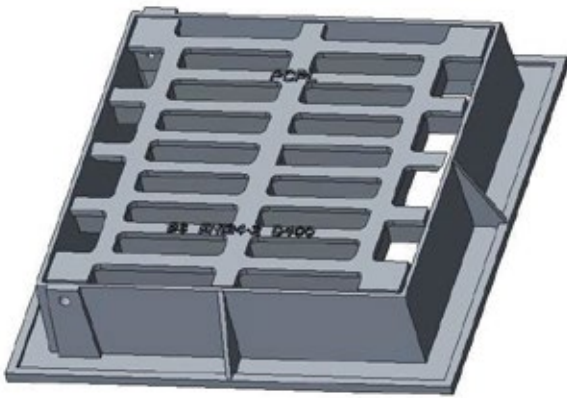

PLAN

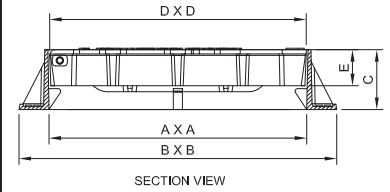

SECTION VIEW

SL. NO.	CLEAR OPENING (A X A)	FRAME (MM)		COVER (MM)	
		OVER BASE (B X B)	HT (C)	OUTSIDE (D X D)	HT (E)
1	300 X 300	400	50	355	35
2	385 X 315	490	100	370	50
3	400 X 400	535	100	405	80
4	420 X 420	555	100	425	80
5	450 X 450	580	100	455	80

DOUBLE TRIANGULAR FRAME AND GRATE (D400)

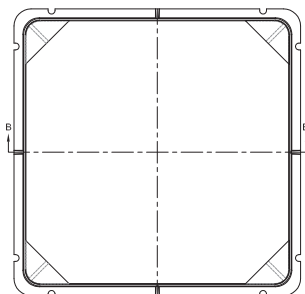

TOP VIEW

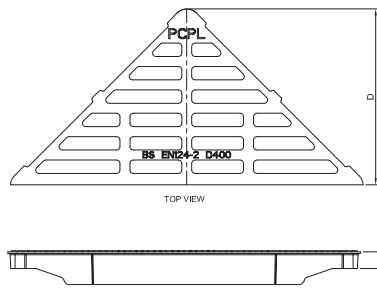

FRONT VIEW

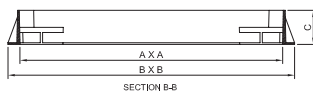
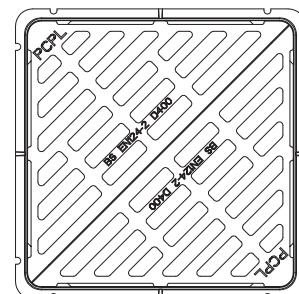

SECTION B-B

SL. NO.	CLEAR OPENING (A X A)	FRAME (MM)		COVER (MM)	
		OVER BASE (B X B)	HT (C)	OUTSIDE (D X D)	HT (E)
1	450 X 450	535 X 600	100	455	50
2	600 X 600	745	95	400	50

CHANNEL GRATING (D400)

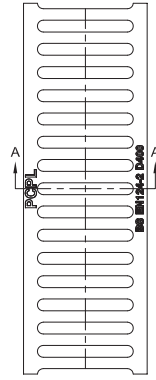

TOP VIEW

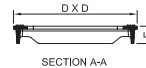

SECTION A-A

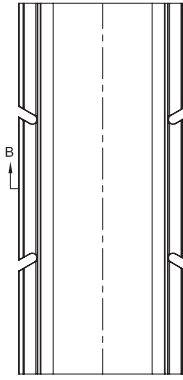

TOP VIEW



SECTION B-B

SL. NO.	CLEAR OPENING (A X A)	FRAME (MM)		COVER (MM)	
		OVER BASE (B X B)	HT (C)	OUTSIDE (D X D)	HT (E)
1	200 X 750	260 X 755	55	200 X 750	40
2	250 X 750	325 X 760	55	250 X 750	45
3	300 X 750	385 X 760	65	300 X 750	55
4	350 X 750	425 X 760	55	350 X 750	45
5	400 X 750	480 X 760	55	400 X 750	45

JRC SOLID TOP FRAME AND COVER (D400)

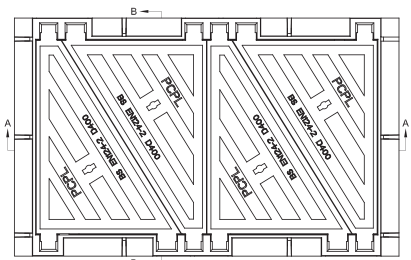

TOP VIEW

D X D

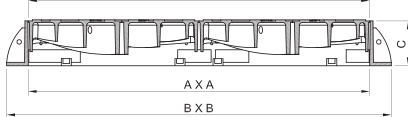

SECTION A-A

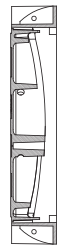

SECTION B-B

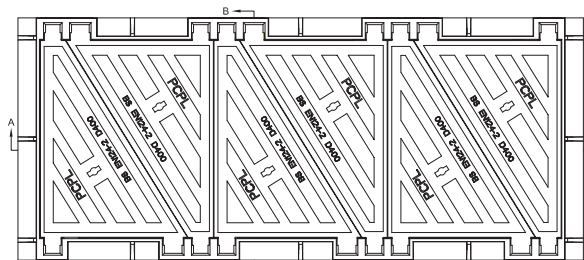

TOP VIEW

D X D

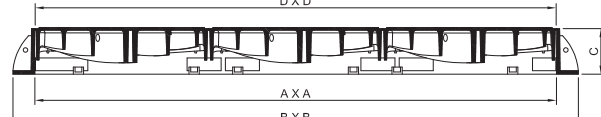

SECTION A-A

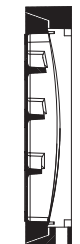

SECTION B-B

SL. NO.	CLEAR OPENING (A X A)	FRAME (MM)		COVER (MM)	
		OVER BASE (B X B)	HT (C)	OUTSIDE (D X D)	HT (E)
1	1200 X 600	1360 X 750	150	1200 X 600	135
2	1500 X 750	1660 X 950	150	1500 X 750	135
3	1200 X 600	1360 X 750	100	1200 X 600	85
4	1500 X 750	1660 X 950	100	1500 X 750	85
5	2250 X 750	2415 X 950	150	2250 X 750	135
6	1200 X 750	1362 X 986	120	1200 X 750	110
7	1800 X 600	1960 X 750	150	1800 X 600	135
8	1896 X 696	2150 X 850	150	1896 X 696	135

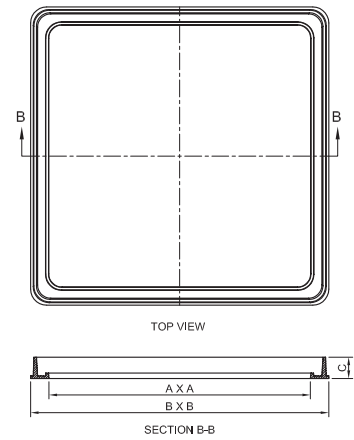
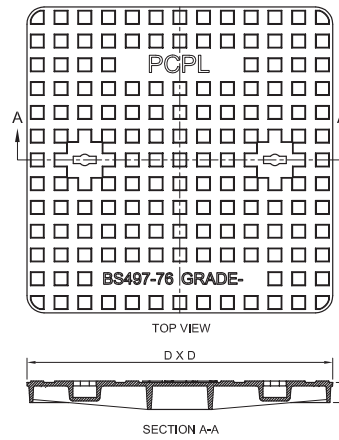
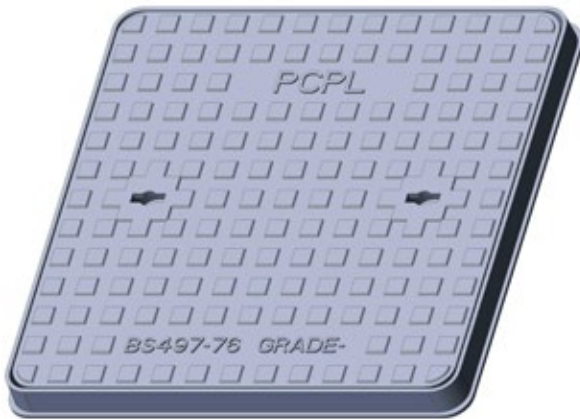

SL. NO.	CLEAR OPENING (A X A)	GR.	WT. (KGS)	FRAME (MM)		COVER (MM)	
				OVER BASE (B X B)	HT (C)	OUTSIDE (D X D)	HT (E)
1	265 X 265	C	9	340	25	315	20
2	300 X 300	C	7	380	20	350	18
3	300 X 300	C	11	370	22	350	18
4	300 X 300	C	13	375	30	340	25
5	300 X 300	B	16	375	30	340	25
6	300 X 300	B	20	375	30	340	25
7	300 X 300	A	35	375	40	340	30
8	450 X 450	C	28	550	40	515	35
9	600 X 600	C	30	695	30	645	25
10	800 X 800	B	90	910	50	865	45

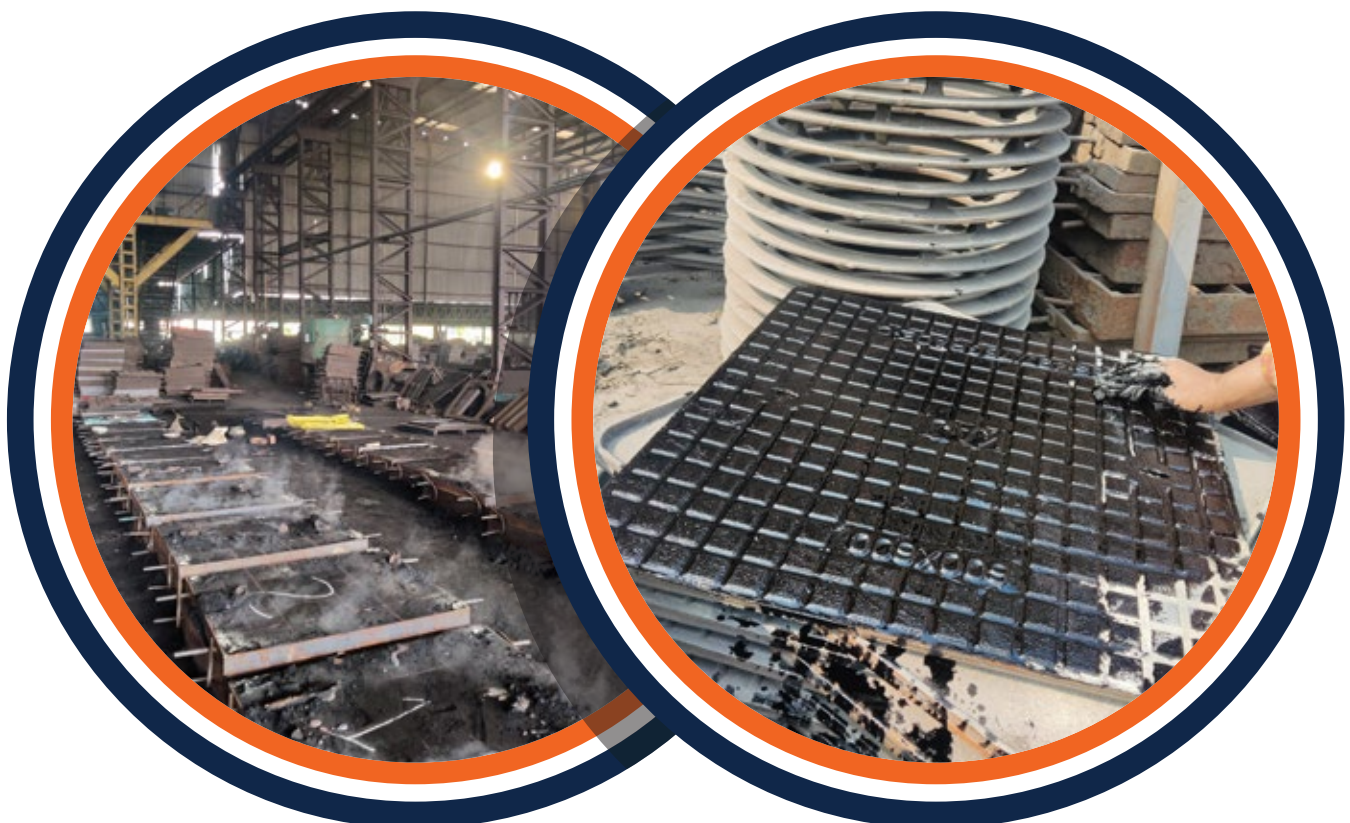

DOUBLE SEAL SOLID TOP FRAME AND COVER

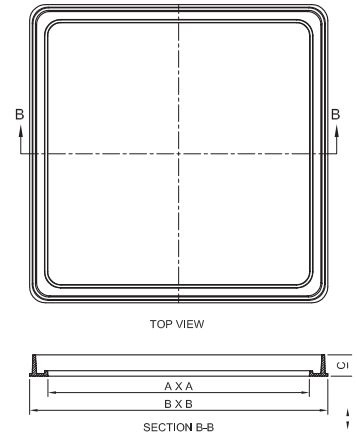
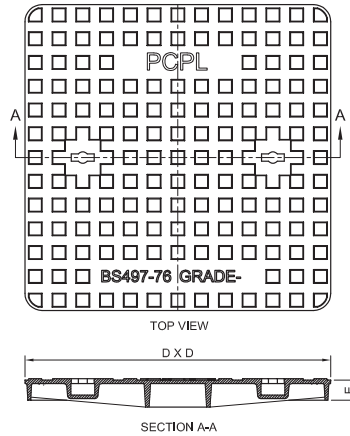
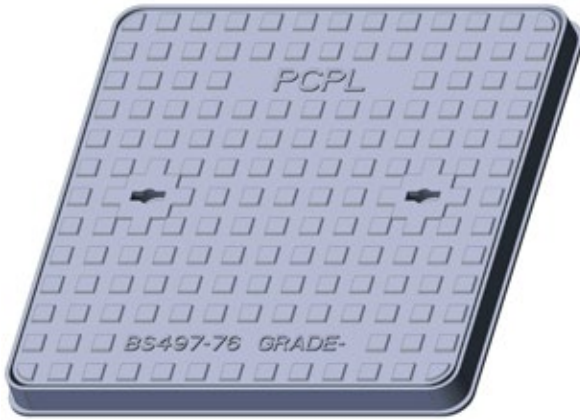

SL. NO.	CLEAR OPENING (A X A)	GR.	WT. (KGS)	FRAME (MM)		COVER (MM)	
				OVER BASE	HT	OUTSIDE	HT
1	300 X 300	C	25	400	40	370	33
2	300 X 300	B	30	400	40	370	33
3	300 X 300	A	45	460	45	420	35
4	450 X 450	B	30	550	40	525	35
5	450 X 450	B	38	570	45	525	35
6	450 X 450	B	45	570	45	525	35
7	450 X 450	A	60	575	45	525	35
8	600 X 600	B	50	750	40	710	35
9	600 X 600	B	70	770	45	710	40
10	600 X 600	B	90	770	75	720	70
11	600 X 600	A	100	760	75	720	70
12	600 X 600	A	110	760	75	720	70
13	600 X 600	A	120	760	75	720	70
14	600 X 600	A	140	760	75	720	70
15	800 X 800	B	110	965	48	915	40
16	800 X 800	A	150	970	50	925	70

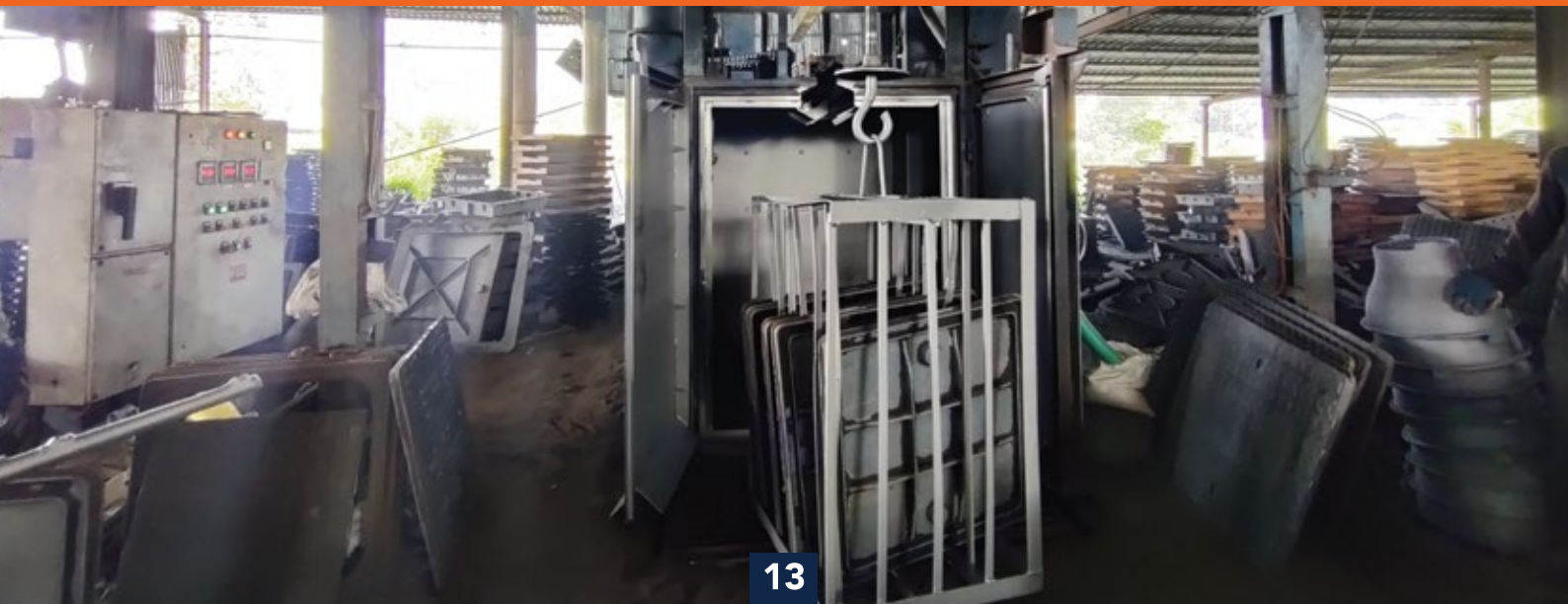

DOUBLE SEAL RECESSED FRAME AND COVER

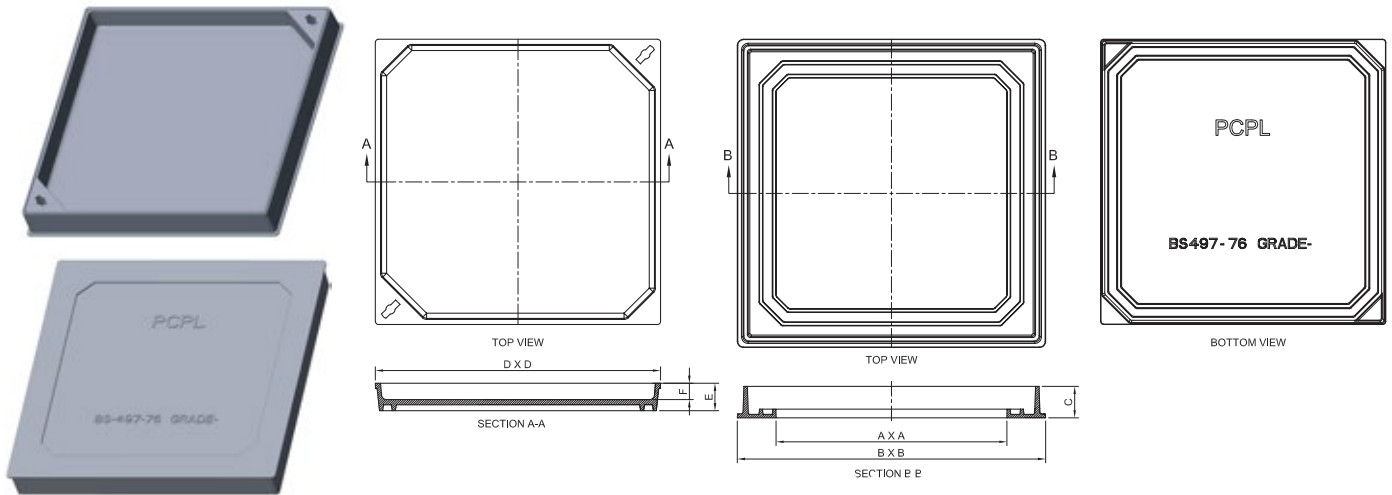

SL. NO.	CLEAR OPENING (A X A)	GR.	WT. (KGS)	FRAME (MM)		COVER (MM)	
				OVER BASE	HT	OUTSIDE	HT
1	300 X 300	B	24	440	65	400	55
2	300 X 300	B	30	445	95	400	90
3	300 X 300	A	35	445	95	400	90
4	450 X 450	B	45	575	65	540	55
5	450 X 450	B	45	615	95	570	85
6	600 X 600	B	60	750	90	705	85
7	600 X 600	B	70	765	95	720	85
8	600 X 600	B	90	765	100	720	90
9	600 X 600	A	110	785	100	740	90
10	600 X 600	A	120	785	100	740	90
11	600 X 600	B	60	755	65	725	60
12	800 X 800	B	120	960	100	915	90

FRAME AND GRATE

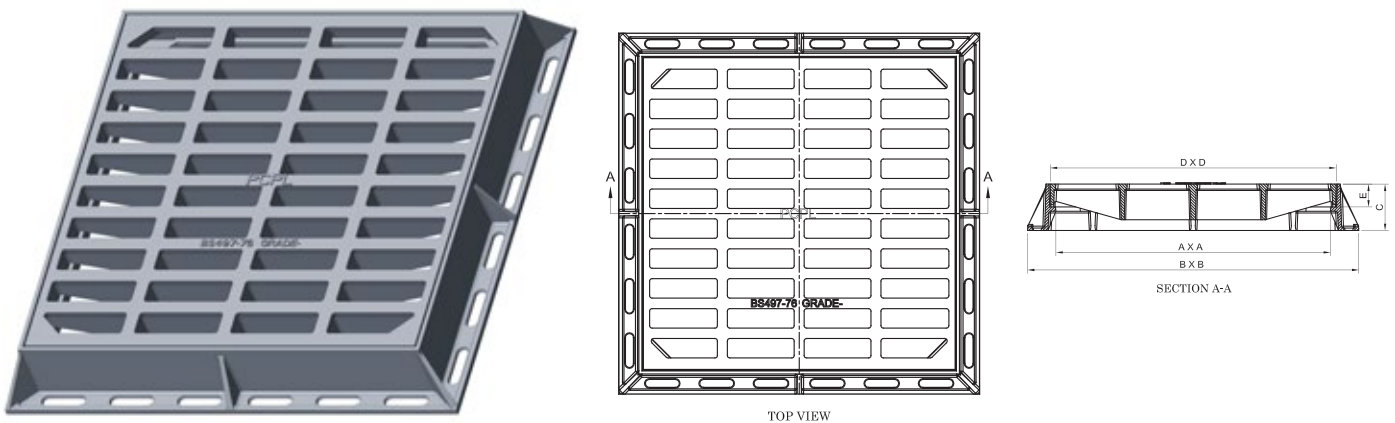

SL. NO.	CLEAR OPENING (A X A)	GR.	WT. (KGS)	FRAME (MM)		COVER (MM)	
				OVER BASE	HT	OUTSIDE	HT
1	300 X 300	B	30	400	50	355	35
2	600 X 600	B	80	690	75	615	35

B125 SINGLE SEAL SOLID TOP COVER AND FRAME



SPAIN

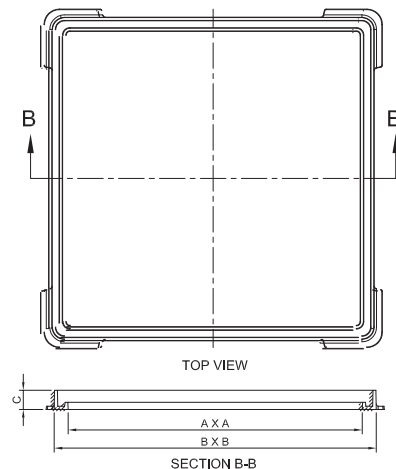
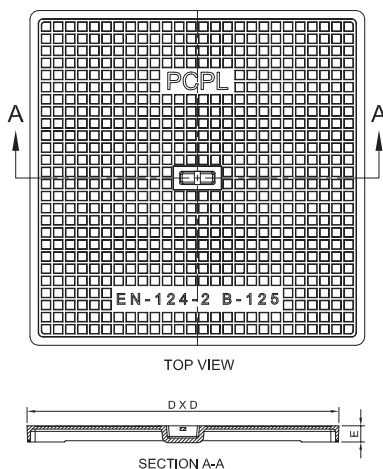

SL. NO.	SIZE	TYPE	GRADE	FRAME (MM)			COVER (MM)	
				OB	CLEAR OPENING	HT	OUTSIDE	HT
1	400 X 400	SINGLE SEAL	B125	420 X 420	365 X 365	24	387 X 387	20
2	500 X 500	SINGLE SEAL	B125	520 X 520	465 X 465	24	487 X 487	20
3	600 X 600	SINGLE SEAL	B125	620 X 620	565 X 565	24	587 X 587	20
4	700 X 700	SINGLE SEAL	B125	720 X 720	665 X 665	24	687 X 687	20

C250 SINGLE SEAL SOLID TOP COVER AND FRAME

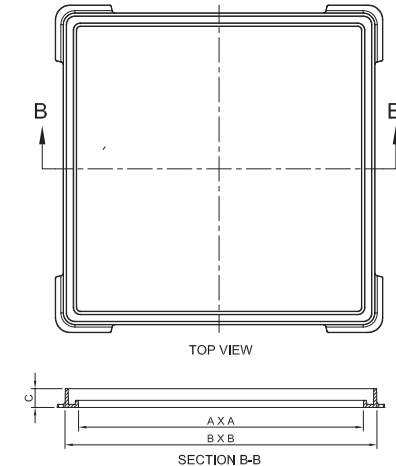
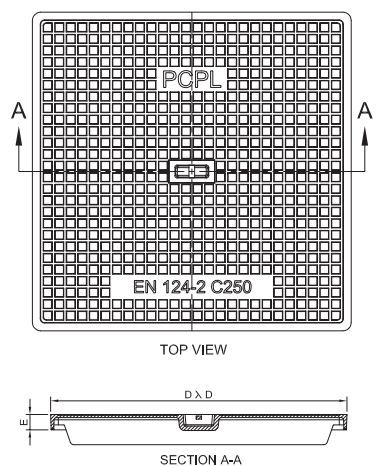

SL. NO.	SIZE	TYPE	GRADE	FRAME (MM)			COVER (MM)	
				OB	CLEAR OPENING	HT	OUTSIDE	HT
1	400 X 400	SINGLE SEAL	C250	420 X 420	354 X 354	40	383 X 383	36
2	500 X 500	SINGLE SEAL	C250	520 X 520	454 X 454	40	483 X 483	36
3	600 X 600	SINGLE SEAL	C250	620 X 620	555 X 555	40	583 X 583	36

D400 SINGLE SEAL CIRCULAR COVER WITH FRAME

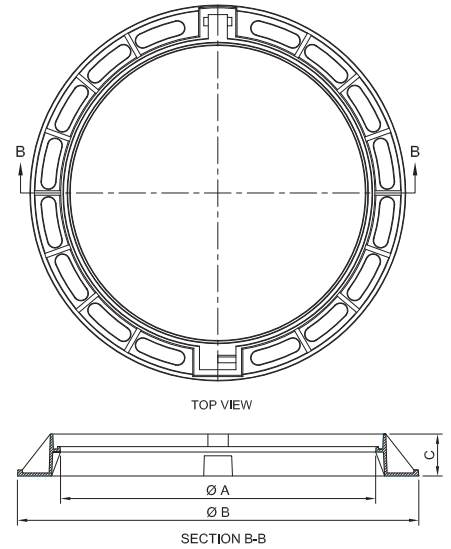
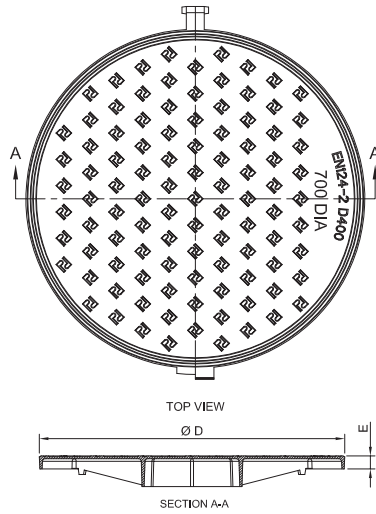

SL. NO.	SIZE	TYPE	GRADE	FRAME (MM)			COVER (MM)	
				OB	CLEAR OPENING	HT	OUTSIDE	HT
1	700 DIA	HINGED	D400	740	562	70	590	22

C250 SINGLE SEAL CIRCULAR COVER WITH FRAME

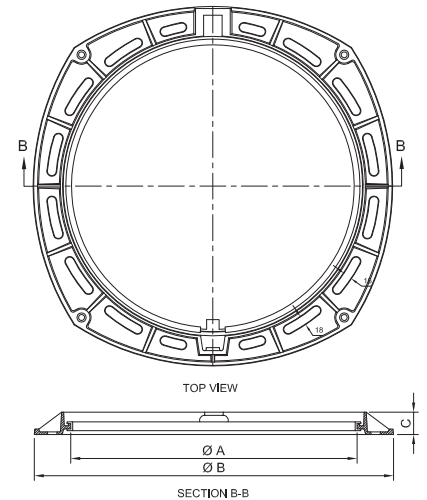
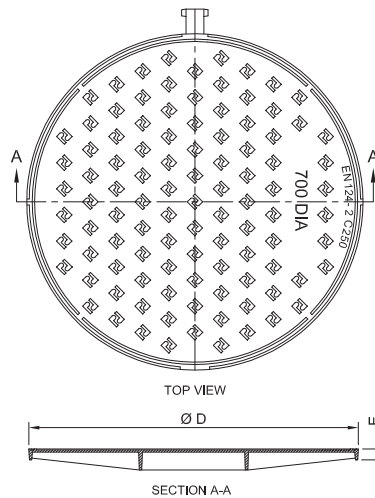

SL. NO.	SIZE	TYPE	GRADE	FRAME (MM)			COVER (MM)	
				OB	CLEAR OPENING	HT	OUTSIDE	HT
1	700 DIA	HINGED	C250	660	526	41	548	18

A15 SINGLE COVER AND FRAME



BELGIUM

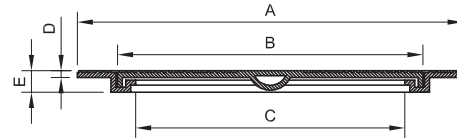
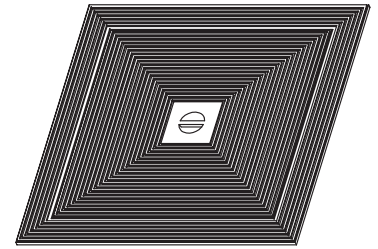
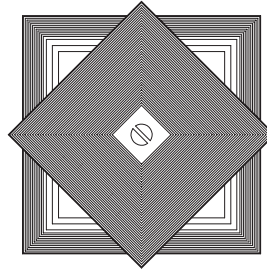
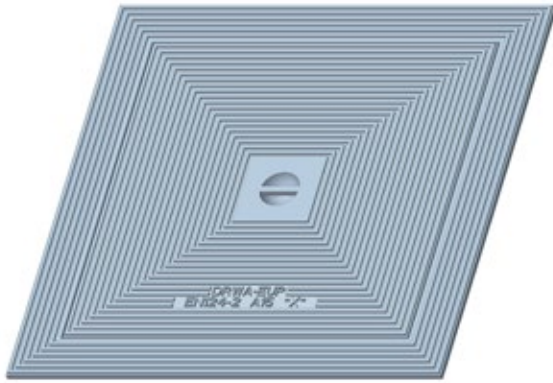

SL. NO.	ITEM "X"	GRADE	TYPE (MM)	A (MM)	B (MM)	C (MM)	D (MM)	E (MM)
1	30X30	A15	300X300	294	200	175	5	20
2	40X40	A15	400X400	394	300	275	5	20
3	50X50	A15	500X500	494	400	370	5	20
4	60X60	A15	600X600	594	500	460	5	20
5	70X70	A15	700X700	694	593	580	5	20
6	80X80	A15	800X800	800	700	680	5	20

A15 DOUBLE COVER AND FRAME

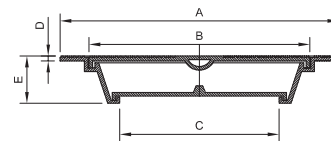
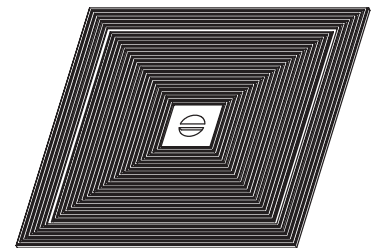
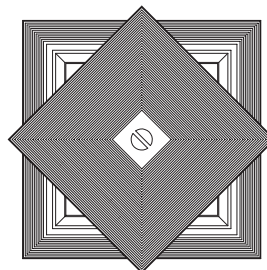
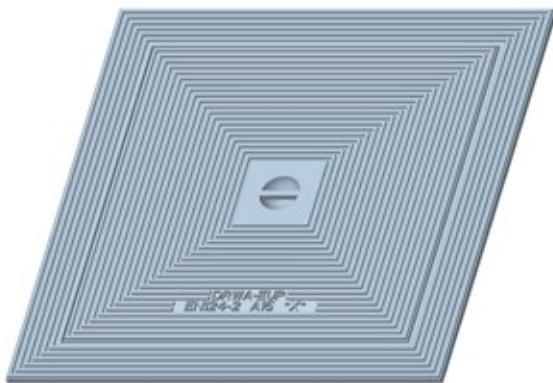

SL. NO.	ITEM "X"	GRADE	TYPE (MM)	A (MM)	B (MM)	C (MM)	D (MM)	E (MM)
1	30X30	A15	300X300	294	200	175	5	60
2	40X40	A15	400X400	394	300	275	5	60
3	50X50	A15	500X500	494	400	370	5	60
4	60X60	A15	600X600	594	500	460	5	60
5	70X70	A15	700X700	694	593	580	5	70
6	80X80	A15	800X800	794	700	680	5	70
7	40X25	A15	400X250	400X250	300X150	232X180	5	55
8	50X30	A15	500X300	500X300	400X200	340X140	5	60
9	60X45	A15	600X450	600X450	500X350	440X290	5	60
10	80X60	A15	800X600	800X600	700X505	640X440	5	80

B125 COVER AND FRAME

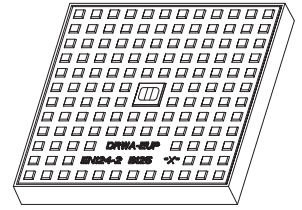
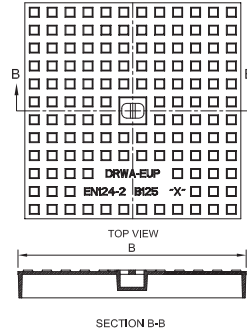
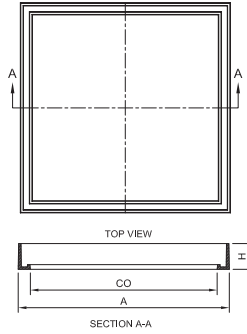
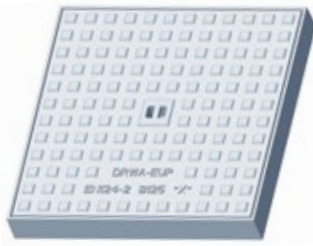

SL. NO.	ITEM "X"	GRADE	FRAME OVER BASE A (MM)	FRAME CLEAR OPEN CO (MM)	COVER OUTSIDE B (MM)	FRAME HIGHT H (MM)	SET WEIGHT (KG.)
1	30X30	B125	300X300	235X180	286X286	30 HT.	7.00 KG.
2	40X40	B125	400X400	330X330	386X386	30 HT.	10.50 KG.
3	50X50	B125	500X500	400X400	486X486	50 HT.	21.50 KG.
4	60X60	B125	600X600	500X500	586X586	50 HT.	29.00 KG.
5	70X70	B125	700X700	600X600	686X686	50 HT.	41.00 KG.
6	80X80	B125	800X800	700X700	786X786	50 HT.	55.00 KG.
7	90X90	B125	900X900	800X800	886X886	50 HT.	73.00 KG.
8	100X100	B125	1000X1000	900X900	984X984	60 HT.	107.00 KG.
9	110X110	B125	1100X1100	1000X1000	1084X1084	60 HT.	125.00 KG.
10	120X120	B125	1200X1200	1200X1200	1184X1184	60 HT.	150.00 KG.

C250 COVER AND FRAME

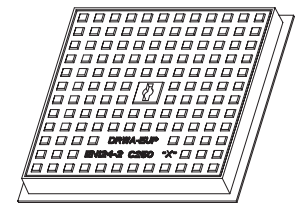
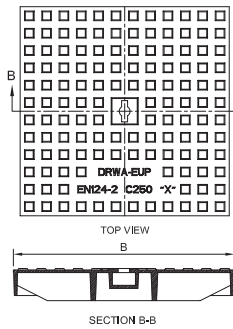
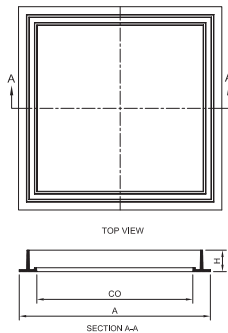
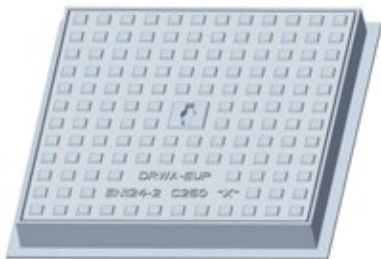

SL. NO.	ITEM "X"	GRADE	FRAME OVER BASE A (MM)	FRAME CLEAR OPEN CO (MM)	COVER OUTSIDE B (MM)	FRAME HIGHT H (MM)	SET WEIGHT (KG.)
1	30X30	C250	300X300	180X180	230X230	55 HT.	13.00 KG.
2	40X40	C250	400X400	280X280	330X330	55 HT.	17.00 KG.
3	50X50	C250	500X500	380X380	430X430	55 HT.	23.00 KG.
4	60X60	C250	600X600	480X480	530X530	55 HT.	36.00 KG.
5	70X70	C250	700X700	580X580	630X630	55 HT.	45.00 KG.
6	80X80	C250	800X800	680X680	730X730	60 HT.	56.00 KG.
7	90X90	C250	900X900	780X780	830X830	60 HT.	70.00 KG.
8	100X100	C250	1000X1000	880X880	930X930	60 HT.	122.00 KG.
9	110X110	C250	1100X1100	980X980	1030X1030	60 HT.	130.00 KG.
10	120X120	C250	1200X1200	1080X1080	1130X1130	60 HT.	160.00 KG.

D400 COVER AND FRAME

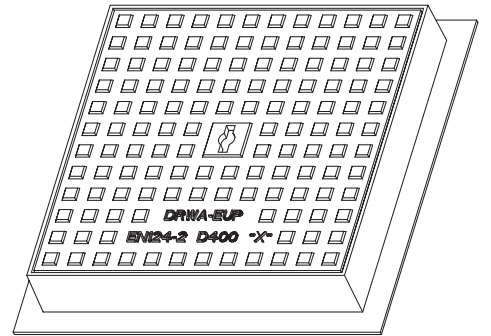
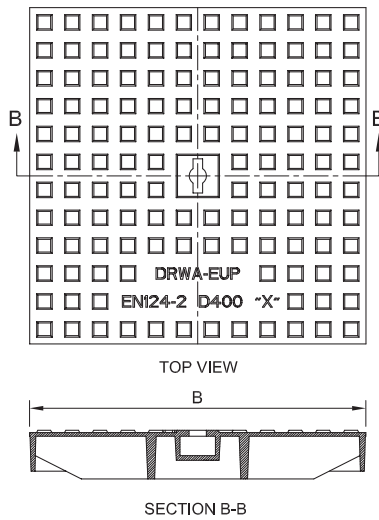
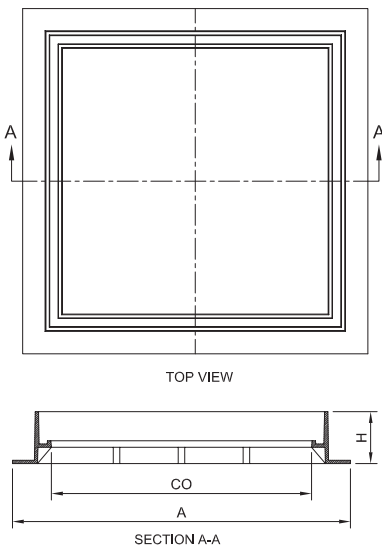
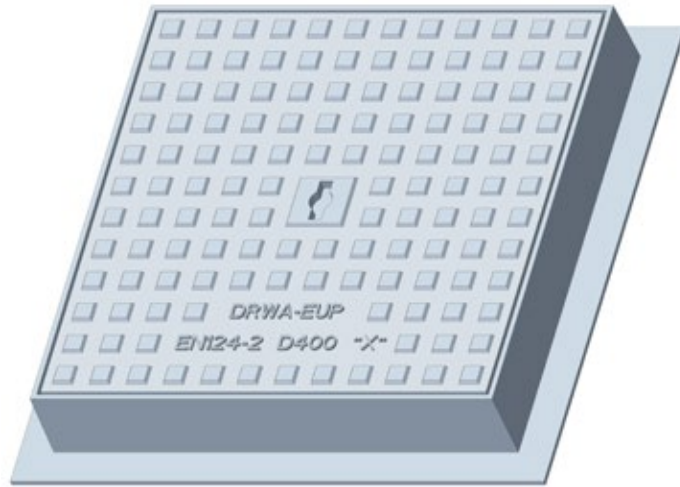

SL. NO.	ITEM "X"	GRADE	FRAME OVER BASE A (MM)	FRAME CLEAR OPEN CO (MM)	COVER OUTSIDE B (MM)	FRAME HIGHT H (MM)	SET WEIGHT (KG.)
1	30X30	C250	300X300	180X180	230X230	55 HT.	13.00 KG.
2	40X40	C250	400X400	280X280	330X330	55 HT.	17.00 KG.
3	50X50	C250	500X500	380X380	430X430	55 HT.	23.00 KG.
4	60X60	C250	600X600	480X480	530X530	55 HT.	36.00 KG.
5	70X70	C250	700X700	580X580	630X630	55 HT.	45.00 KG.
6	80X80	C250	800X800	680X680	730X730	60 HT.	56.00 KG.
7	90X90	C250	900X900	780X780	830X830	60 HT.	70.00 KG.
8	100X100	C250	1000X1000	880X880	930X930	60 HT.	122.00 KG.
9	110X110	C250	1100X1100	980X980	1030X1030	60 HT.	130.00 KG.
10	120X120	C250	1200X1200	1080X1080	1130X1130	60 HT.	160.00 KG.

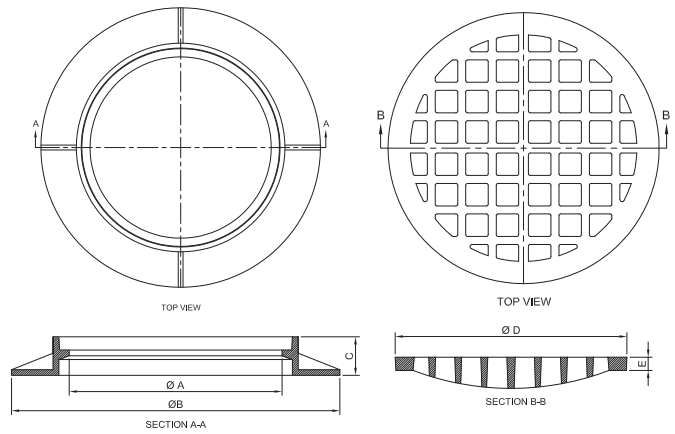

SL. NO.	CLEAR OPENING (MM)	FRAME (MM)		COVER (MM)	
		OB	HT	OUTSIDE	HT
1	22 DIA	34 DIA	4	24 DIA	1.5
2	22 DIA	34 DIA	6	24 DIA	3.5
3	22 DIA	34 DIA	8	24 DIA	5.5

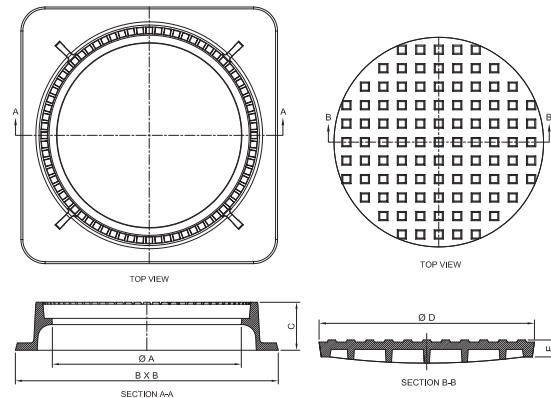
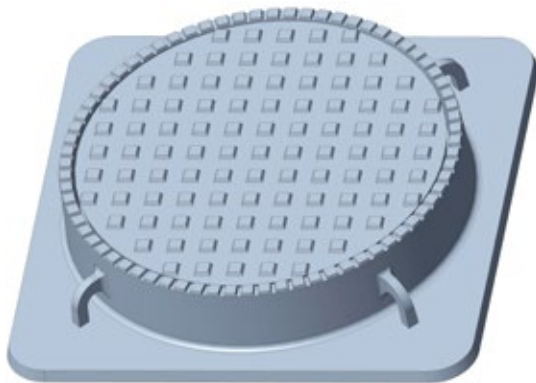
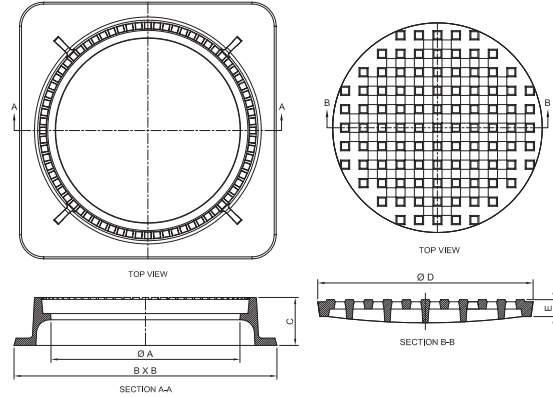
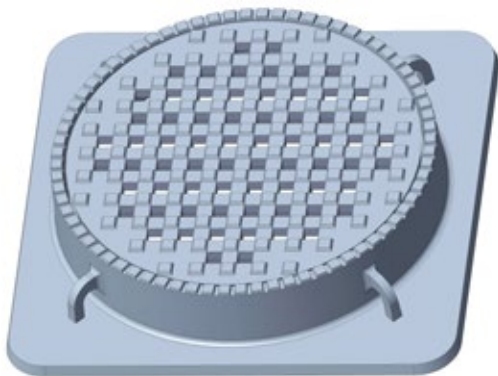

SL. NO.	CLEAR OPENING (MM)	FRAME (MM)		COVER (MM)	
		OB	HT	OUTSIDE	HT
1	575 DIA	800 X 800	146	624 DIA	49
2	575 DIA	800 X 800	152	624 DIA	89
3	575 DIA	800 X 800	204	624 DIA	140

TACTILE PLATE

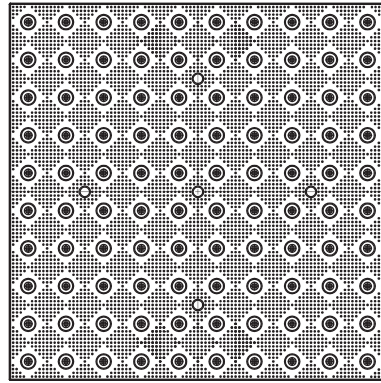
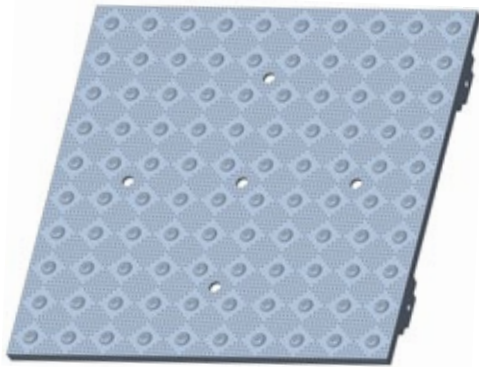

TOP VIEW



SIDE VIEW

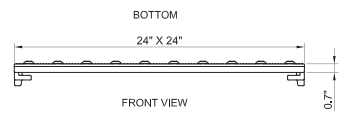
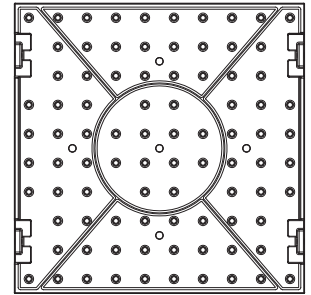

SL. NO.	TILE SIZE	COVER (INCH)	
		OUTSIDE	HT
1	24 X 24	24 X 24	24
2	17.5 X 24	17.5 X 24	24
3	18.5 X 22	18.5 X 22	24

4 INCH / 5 INCH VALVE BOXES



TOP / BOTTOM FLANGE

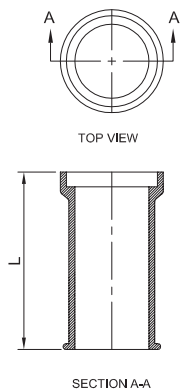

BELL BOTTOM

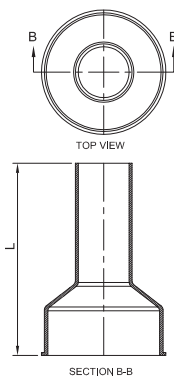

EXTENSION

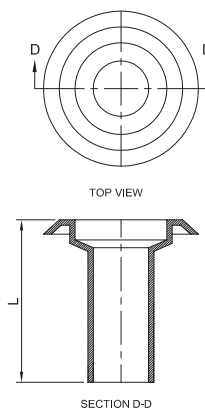
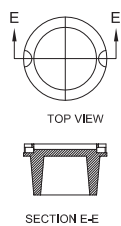
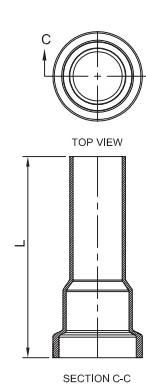

1000X1000 DT D400 LUSAIL CITY FRAME AND COVER



QATAR

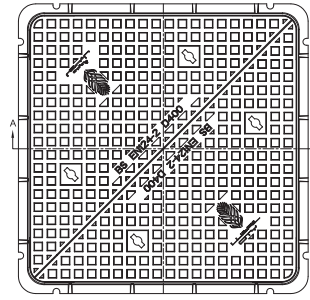
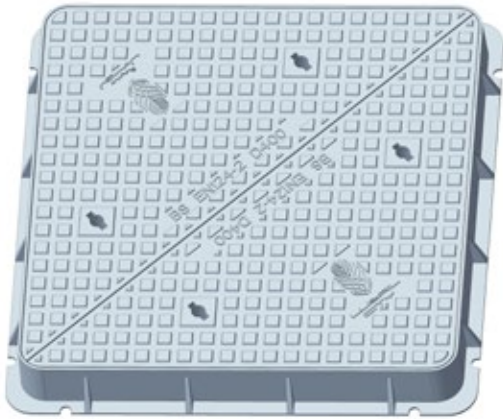

TOP VIEW

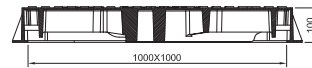

SECTION A-A



1000X1000 DT D400 KAHARMAA FRAME AND COVER

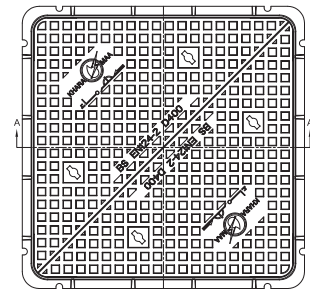

TOP VIEW

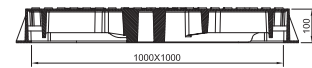

SECTION A-A



FACTORY PICTURES

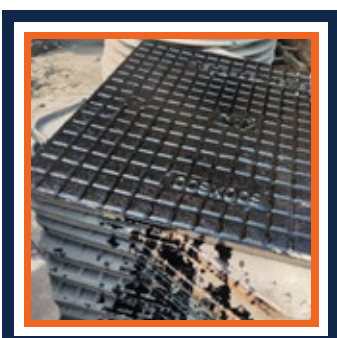
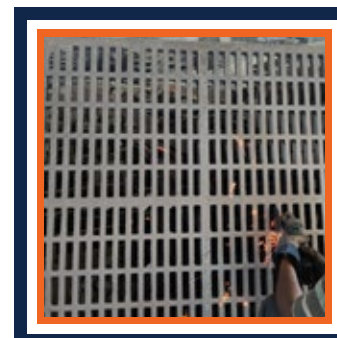
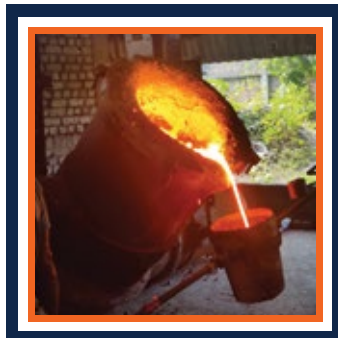

PRODUCTION PROCESS

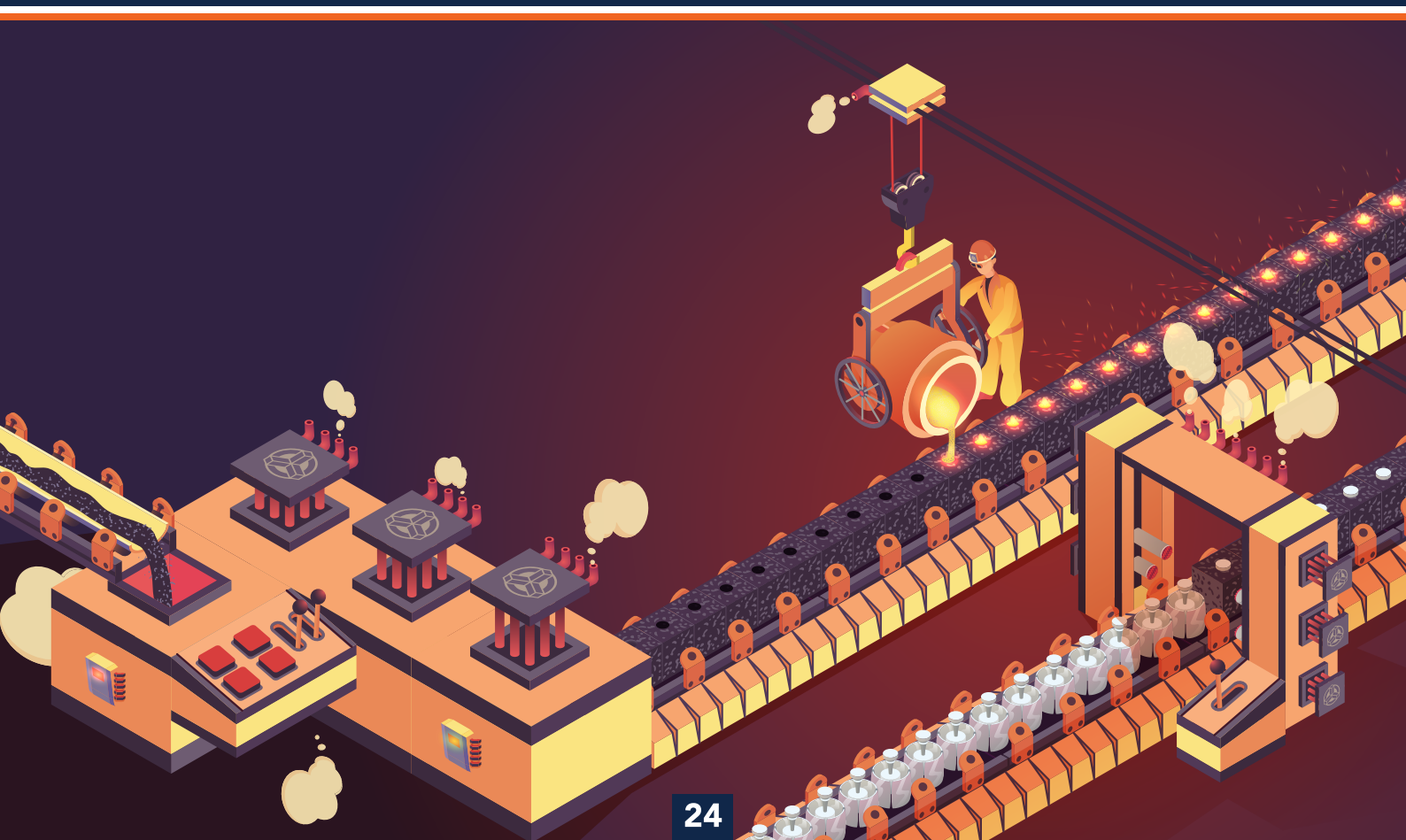
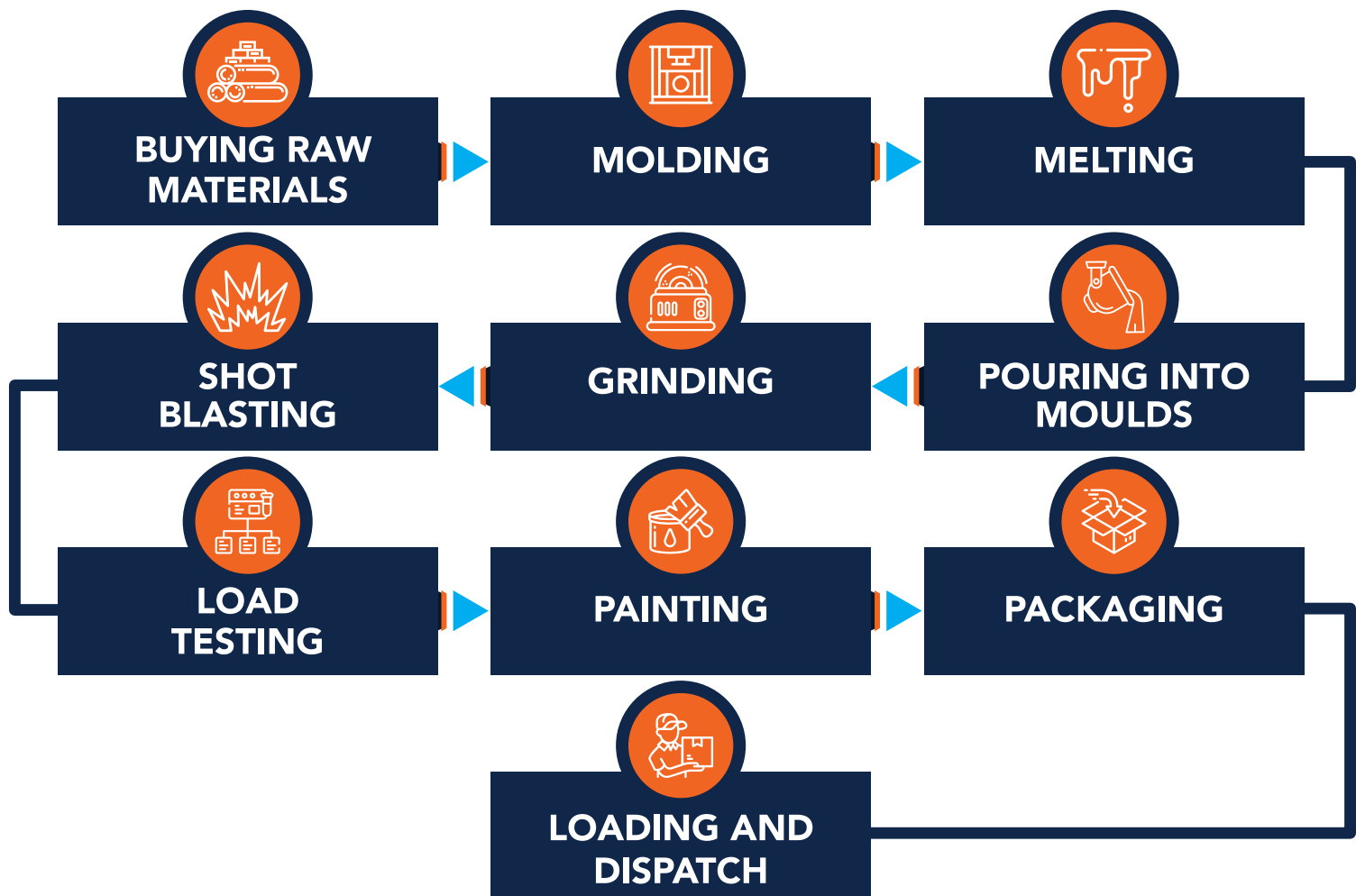

OUR PRODUCTS

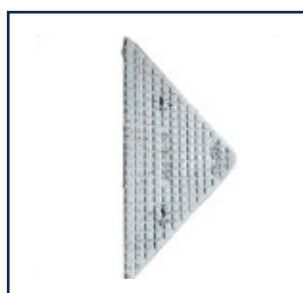
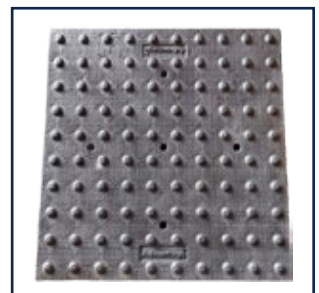
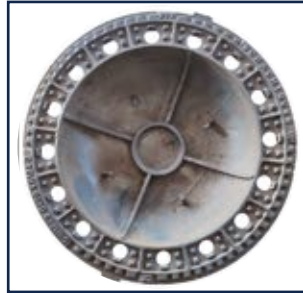

OVER THE YEARS



2018

Started the set up of the plant in october 2018.

2019

Completed the entire set up, approvals . commenced commercial production in june 2019.

2020

Since it was the pandemic year, we spent time to set up robust internal processes to streamline operations and build a quality oriented culture in the company.

2021

Started the production of ductile castings. get the iso registration within a few months of operations developed castings for various sectors such as exports, earth moving equipment, mining etc. to build a customer base.

2022

Focusing on niche markets – like europe and middle east for sanitary castings and other core industrial sectors. measures to sustain and improve the internal systems through quality assurance programs such as 5s.

FUTURE PLANS



- As an organization our aim is to deliver quality castings with a commitment on the service and delivery.
- Our vision is to continuously innovate with regards to our product portfolio and customize our product development process to suit customer needs.
- Our primary focus will be manufacturing of iron castings. we want to be india's leading casting manufacturers who specialize in iron castings





Primary Castings Pvt. Ltd.

 Mouza: Rajpura & Malancha, Tata Metaliks Road,
Sahachowk Kharagpur, West Midnapore-721301,
West Bengal, India

 www.pcpl.in

 primarycastings@gmail.com

 +91 9433038999